

Neural Observer Based Spasticity Quantification during Therapeutic Muscle Stimulation

Michael Bernhardt, Bernhard Angerer, Martin Buss and Albrecht Struppler

Abstract—Repetitive peripheral magnetic stimulation (RPMS) is an innovative approach in treatment of central paresis, e.g. after stroke. The main goals of our current research are the improvement of the therapeutic effect by inducing closed loop controlled movements on the one hand, and the objective assessment of the RPMS therapy on the other hand. One important parameter that allows the evaluation of the therapy progress and that gives insight in neurological processes is the level of spasticity. Current methods to evaluate spasticity are not completely objective and error-prone. This paper presents a novel method of spasticity quantification. The used algorithms are based on parameter estimation methods and can be executed during the therapeutic stimulation. Hence, objective spasticity parameters can be obtained without applying any extra equipment. The presented method has been tested with one patient.

I. INTRODUCTION

A central paresis of the arm and/or hand, e.g. after stroke, reduces the quality of life dramatically. Studies on large clinical cohorts, using standard therapeutic methods, showed that approximately 90% of stroke patients have persistent hemiparesis of the upper extremities, and in 30-40% the paresis is that severe that the affected limb can not used any more. This data indicates the importance of innovative approaches in rehabilitation of central paresis.

Cortical reorganization probably forms the basis of re-learning of lost motor functions. Morphological and functional investigations on central paresis revealed that the sensorimotor cortex retains a great capability to adapt to altered afferent input [1].

In order to activate a beneficial reorganization process, the lost proprioceptive input should be reactivated. Currently physiotherapy aims to achieve such an activation through externally applied movements. When the lost movements are induced by muscle stimulation, the proprioceptive input is much higher and corresponds closer to the lost voluntary action patterns which increases the therapeutic effect [2].

In this context the functional electrical stimulation (fES) is a well-known method. However, the fES not only activates somatosensory nerve fibers, but also cutaneous receptors

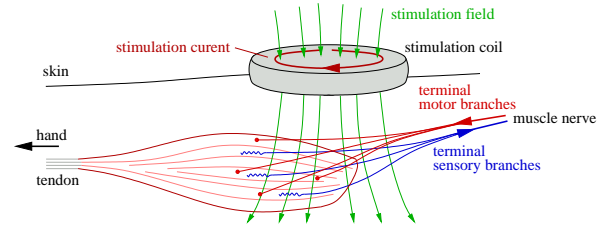

Fig. 1. Principle of the RPMS application

which may cause pain and increase spasticity. Therefore the usability of fES for therapeutic purposes is limited [3, e.g.].

As a new, deeper penetrating, focused and painless stimulation method, repetitive peripheral magnetic stimulation (RPMS) is used (fig. 1). The repetitive applied field impulses are sinusoidal half-waves with a fixed duration of $100\mu\text{s}$ and a variable amplitude called stimulation intensity. The maximum stimulation intensity of 100% corresponds to a magnetic flux density of approximately 2.0T.

The therapeutic concept of RPMS is the activation of a reorganization process by inducing a proprioceptive input to the CNS, physiologically corresponding to the lost input during active movements [2, e.g.]. In clinical experimental studies [4] on spasticity, cognitive functions, cerebral activation, stiffness around the elbow joint and goal-directed motor performances, it could be shown, that the sensorimotor dysfunctions due to brain lesions can be remarkably improved by RPMS.

Our research focuses on the improvement and the assessment of the RPMS-therapy. To optimize the proprioceptive inflow, it is necessary to induce coordinated movements by stimulation of multiple muscle groups. Hence, a nonlinear closed loop control of a grasping movement of the index finger and the thumb as depicted in fig. 2, combined with automated assessment tools is the overall target. Parameter identification methods as described in the following section are applied in order to adapt the controller to the patient on the one hand and to extract data that allows to objectively assess the rehabilitation process on the other hand. One important goal in treatment of central paresis is the reduction of spasticity. The evaluation of the spasticity level is essential for the individual therapy planning, for the evaluation of the therapy progress and most of all for the neurological research to obtain a deeper understanding of the recovery processes in the central nervous system (CNS). Standard methods are the modified Ashworth scale [5] or EMG-measurements of the affected muscles. The modified Ashworth test is not

This work has been supported by the Deutsche Forschungsgemeinschaft. M. Bernhardt is with the Sensorimotor Research Group, Klinikum r. d. Isar, Munich, Germany and with the Institute of Automatic Control Engineering, Technische Universität München, Munich, Germany bernhardt@tum.de

B. Angerer and A. Struppler are with the Sens. Res. Group, Klinikum r. d. Isar, Munich, Germany, bernhard.angerer@tum.de struppler@lrz.tum.de

M. Buss is with the Institute of Automatic Control Engineering, Technische Universität München, Munich, Germany mb@tum.de

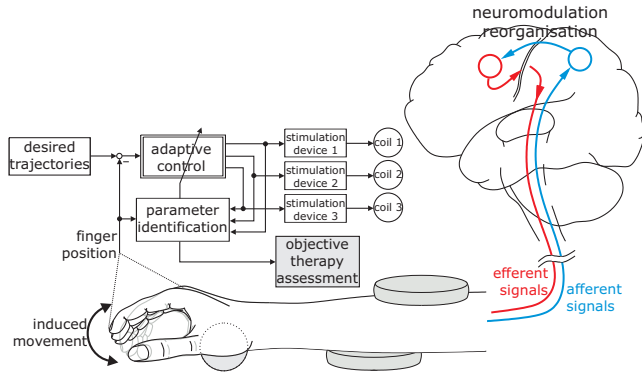

Fig. 2. Planned rehabilitation environment that allows to perform the therapy and its evaluation at once. During the position controlled induction of a grasping movement, plant parameters are identified online in order to adapt the controller and to monitor the patient

objective and EMG-measurements are time consuming and error-prone. In [6] static and dynamic spasticity components are identified by measuring the torque necessary to passively move the elbow joint, and in [7] a system identification approach is introduced which is also based on torque measurements. For both methods extra equipment like force sensors is needed.

In this paper a new method of spasticity evaluation is presented that can be accomplished fully automated during the therapy, without performing additional tests afterwards. It delivers objective data that can be obtained time continuous during the therapy. As a first step, the spasticity evaluation has been tested with an open loop stimulation of the musculus indicis proprius (extensor muscle of the index finger) of a hemiplegic patient with a spastic paretic hand (spasticity of the wrist flexors and finger flexors).

II. METHODS

In this section a *RPMS* induced index finger extension will be mathematically described with a simplified model including the spasticity as a time-variant nonlinear function. Then, parameter identification methods will be introduced that identify changes of spasticity.

A. Model of the index finger extension

The model of the stimulated muscle and the index finger (fig. 3) comprises the force generation, the segment dynamics as well as muscle contraction dynamics (also known as Hill's muscle model). As described in [8], the force generation can be modelled as a nonlinear function $r(u)$ (number of recruited motor units) and an PT3-system with three identical real poles (force response of a single recruited motor unit). Hill's muscle model describes the dependency of the force generation on the muscle length and the muscle velocity. Since simulative results showed its small influence on our experiments, it will be neglected for further considerations. The segment dynamics describe the rotation ($\varphi, \dot{\varphi}, \ddot{\varphi}$) of the metacarpophalangeal (MCP) joint. It comprises the moment of inertia J and two nonlinear functions $N_1(\varphi)$ and $N_2(\dot{\varphi})$. These functions comprise the gravitational torque $f_g(\varphi)$, the

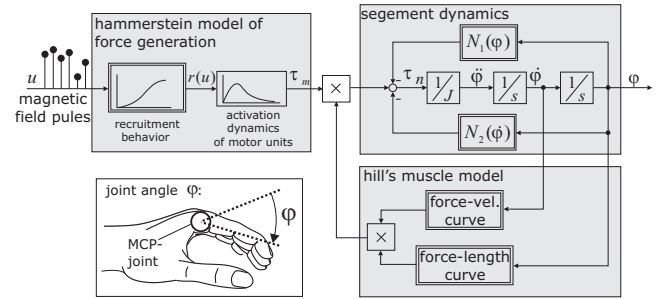

Fig. 3. Simplified model of the plant

passive elastic joint properties $f_{ejp}(\varphi)$ and friction effects $f_f(\dot{\varphi})$. In the typical case of a patient with a flexor spasticity the model has to be extended. Spasticity is a disinhibition of the muscle flexor reflexes and the muscle tone due to the lesion in the CNS. It depends on the actual length of the respective muscle and can also be activated by a muscle movement. Hence the flexor spasticity in the forearm can be modelled as functions of the position φ and the velocity $\dot{\varphi}$ of the MCP joint. Although this is not an entirely correct model of the physiological structure, the joint torques generated by the spasticity will be described within $N_1(\varphi)$ and $N_2(\dot{\varphi})$ and we obtain

$$N_1(\varphi) = f_g(\varphi) + f_{ejp}(\varphi) + s_s(\varphi, t), \quad (1)$$

$$N_2(\dot{\varphi}) = f_f(\dot{\varphi}) + s_d(\dot{\varphi}, t). \quad (2)$$

The spasticity is described as time variant functions $s_s(\varphi, t)$ (static/tonic component) and $s_d(\dot{\varphi}, t)$ (dynamic/phasic component) whereas the time variance is much slower than the system dynamics. Since the rest of the plant is extensively time invariant, changes of plant parameters must be due to the varying spasticity. Thus, the change of spasticity can be observed with a time continuous parameter identification of the plant.

B. Parameter Identification

In the used approach for the nonlinear parameter identification the nonlinearities $r(u)$, $N_1(\varphi)$ and $N_2(\dot{\varphi})$ are described as normalized radial basis function (NRBF) networks and the impulse response of the motor units as a truncated convolution sum. The NRBF network is defined by its activation functions:

$$A_l(u) = \frac{\mathcal{E}_l}{\sum_{j=1}^p \mathcal{E}_j} \text{ with } \mathcal{E}_l = \exp\left(-\frac{(u - \chi_l)^2}{2\sigma^2}\right) \quad (3)$$

and their respective network weights θ_l . $\chi_l \in \mathbb{R}$ are the centers and $\sigma \in \mathbb{R}^+$ is a smoothing parameter of A_l . For sake of simplicity the following steps are calculated in discrete time domain with $t = kT_s$. (The algorithms are implemented with a sample time of $T_s = 0.001$ s.) Hence, the recruitment function can be written as $r(u[k]) = \underline{\theta}_r^T \underline{A}_r(u[k]) = \sum_{l=1}^m \theta_{r,l} A_{r,l}(u[k])$. Including $r(u[k])$ in the convolution sum of the truncated impulse response $h[i]$ leads

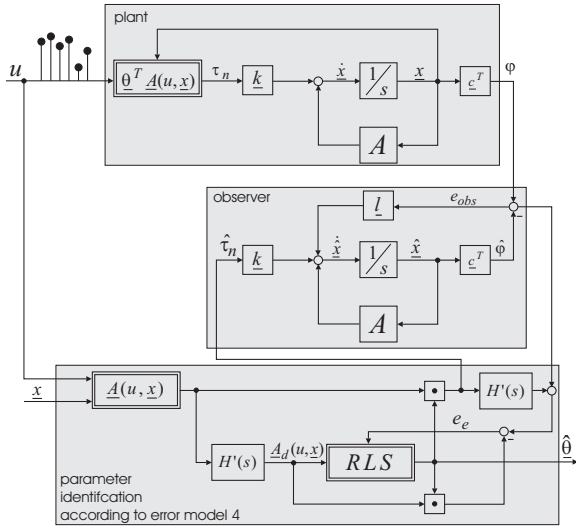

Fig. 4. Identification structure according to error model 4 combined with a state observer (neural observer).

to

$$\tau_m[k] = \sum_{l=1}^m \sum_{i=1}^n h[i] \theta_{r,l} A_{r,l}(u[k-i]) = \underline{\theta}_m^T \underline{A}_m(u[k]) . \quad (4)$$

The theory and the capabilities of this approach in conjunction with *RPMS* are described in [9]. If $N_1(\varphi)$ and $N_2(\dot{\varphi})$ are also modelled as NRBF networks and with $\underline{x} = [\varphi \ \dot{\varphi}]^T$, the net joint torque $\tau_n[k]$ can be written as

$$\begin{aligned} \tau_n[k] &= \underline{\theta}_m^T \underline{A}_m(u[k]) + \underline{\theta}_{N1}^T \underline{A}_{N1}(\varphi[k]) + \underline{\theta}_{N2}^T \underline{A}_{N2}(\dot{\varphi}[k]) \\ &= \underline{\theta}^T \underline{A}(u[k], \underline{x}[k]) . \end{aligned} \quad (5)$$

The goal of the parameter identification is now to compute an optimal estimate parameter vector $\hat{\underline{\theta}}$. Using the recursive least squares method (RLS) with a feedback of the output error $e = \tau_n - \hat{\underline{\theta}}^T \underline{A}(u, \underline{x})$ we obtain

$$\hat{\underline{\theta}}[k] = \hat{\underline{\theta}}[k-1] + \underline{\gamma}e \quad (6)$$

as adaptation algorithm, whereas $\underline{\gamma}$ is the so called Kalman vector (see e.g. [10] for details). In our case the output error e can not be calculated since the net joint torque τ_n is not directly measurable. In [11] methods are introduced that allow a stable parameter identification even though the model error is filtered by an error transfer function $H(s)$. The so called error model 4 is the most general approach. The basic idea of error model 4 is to filter the activation vector $\underline{A}(u, \underline{x})$ with the error transfer function $H(s)$ and to build an extended error e_e in order to feed a delayed activation vector $\underline{A}_d(u, \underline{x})$ and e_e into the adaption algorithm (fig. 4, lower part). Here, $\hat{\tau}_n$ would have to be filtered with $H(s) = 1/Js^2$ (fig. 3) which does not meet the requirement of $H(s)$ to be asymptotically stable. However, in [12] a neural observer is introduced as a combination of error model 4 with a state observer in order to obtain an asymptotically stable error transfer function $H'(s)$ (fig. 4 middle part).

As derived in [11], the error transfer function describes the behavior between the output of the modelled nonlinearity (here $\hat{\tau}_n$) and the estimated system output (here $\hat{\varphi}$). With

$$A = \begin{bmatrix} 0 & 1 \\ 0 & 0 \end{bmatrix} \quad \underline{k} = \begin{bmatrix} 0 \\ 1/J \end{bmatrix} \quad \underline{c} = \begin{bmatrix} 0 \\ 1 \end{bmatrix} \quad \underline{l} = \begin{bmatrix} l_1 \\ l_2 \end{bmatrix} \quad (7)$$

we obtain

$$H'(s) = \underline{c}^T (sE - A + \underline{l}\underline{c}^T)^{-1} \underline{k} = \frac{1/J}{s^2 + sl_2 + l_1} . \quad (8)$$

C. Model Reconstruction

The estimate functions $\hat{r}(u)$, $\hat{h}(t)$, $\hat{N}_1(\varphi)$ and $\hat{N}_2(\dot{\varphi})$ have to be reconstructed from the parameter vector $\hat{\underline{\theta}}$. Since the reconstruction is not unique, meaningful constraints have to be formulated. For the separation of $\hat{r}(u)$ and $\hat{h}(t)$ from $\hat{\underline{\theta}}_m$ it is useful to introduce the constraint so that the reconstructed impulse response $\hat{h}(t)$ has a gain of one (final value of the corresponding step response: $g_\infty = \sum_{i=0}^n \hat{h}[i]$). Since the real system is activated by magnetic field pulses at a frequency of $f_{stim} = 20\text{Hz}$ it is suggestive not to normalize the final value of a step response but the final value of a system activation with impulses at 20Hz. Hence, the first constraint can be easily derived as

$$20\text{Hz} \cdot T_s \sum_{i=0}^n \hat{h}[i] = 1 . \quad (9)$$

For a unique reconstruction of $\hat{N}_1(\varphi)$ and $\hat{N}_2(\dot{\varphi})$, the friction and the dynamic spasticity component are set to zero at the angular velocity $\dot{\varphi} = 0$, which leads to

$$\hat{N}_2(0) = 0 . \quad (10)$$

III. EXPERIMENTAL RESULTS

The method described above has been tested experimentally with one patient (female, 71 years old, hemiplegic after stroke, spastic paretic hand with neglect syndrome). In clinical experimental studies it could be shown, that the level of spasticity decreases after the application of conditioning *RPMS* [2]. During the treatment, nonfunctional muscle contractions are applied to the flexor and extensor muscles of the forearm and the upper arm. The field pulses are applied for a period of 1.5s followed by a break of 3s with a total duration of approximately 15min. In order to assess the change of spasticity due to the conditioning *RPMS*, the angle $\varphi(t)$ of the MCP joint of the index finger and the stimulation intensity $u(t)$ have been recorded during open loop stimulation of the index finger extensor immediately before (time t_1) and one hour after (time t_2) the treatment. These two data sets have been used to identify the plant parameters as described in section II.

The results of the reconstruction are depicted in fig. 5 and fig. 6. The differences $\hat{r}_1(u)$ and $\hat{r}_2(u)$ are due to slightly different positions and orientations of the coils on the forearm since the recruitment characteristics model the number of activated motor units. The reconstructed activation dynamics $\hat{h}(t)$ cannot be a correct model of the force

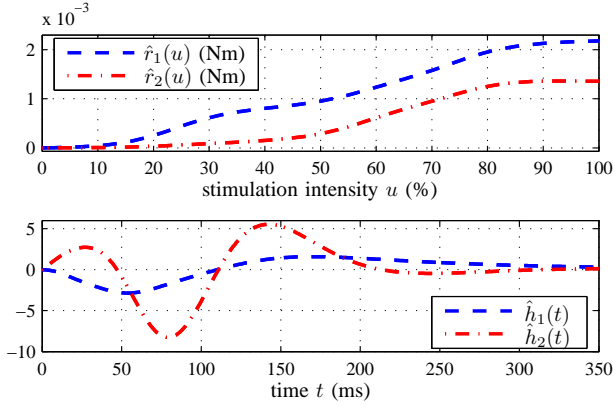

Fig. 5. Identified and reconstructed recruitment characteristics $\hat{r}(t)$ and activation dynamics $\hat{h}(t)$

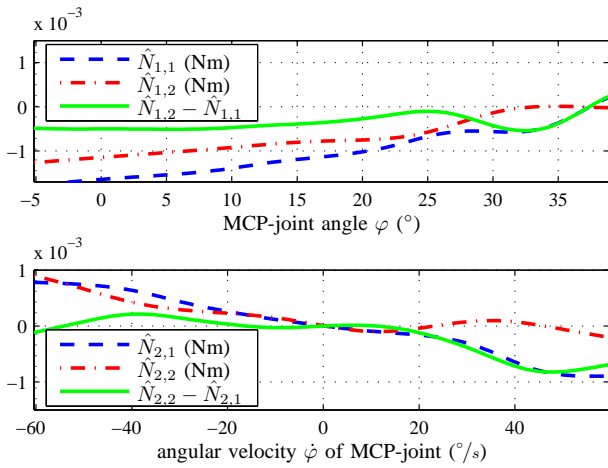

Fig. 6. Identified and reconstructed nonlinearities $\hat{N}_1(\varphi)$ and $\hat{N}_2(\dot{\varphi})$

response since negative responses are physiologically impossible. As mentioned in section II experiments with force measurements under isometric conditions delivered a PT₃-model of $\hat{h}(t)$ with a shape that is indicated in fig. 3. 48 of the 64 parameters are needed to model $\hat{h}(t)$. Since the adaptation algorithm will try to cope with model inconsistencies like sensor noise, voluntary activity, hysteresis, etc. by adapting the function with the highest number of degrees of freedom, the result of $\hat{h}(t)$ is not very reliable.

The result of the spasticity evaluation is depicted in fig. 6. The solid line describes is the difference between the nonlinear functions identified at the time t_2 and t_1 . With eq. (1) we obtain the change of static spasticity

$$\Delta\hat{s}_s(\varphi) = \hat{N}_1(\varphi)\Big|_{t_2} - \hat{N}_1(\varphi)\Big|_{t_1}. \quad (11)$$

The change of the dynamic component $\Delta\hat{s}_d(\varphi)$ can be calculated accordingly. The identification result of fig. 6 clearly indicates a decrease of the static flexor spasticity component. The dynamic component has increased slightly for extension movements and decreased for flexion movements. These results coincide with the findings of the medical examinations.

IV. CONCLUSION AND FUTURE WORK

A. Conclusion

This paper presents a novel method for spasticity evaluation. The presented method delivers objective data and can be executed during the therapeutic stimulation without applying any extra equipment. Furthermore it delivers a clear separation between the static and dynamic spasticity component. Hence, it can be a valuable tool for rehabilitation research to help understanding the processes of recovery after stroke. It can also help the physiotherapist to monitor the therapy process and hence, to adapt the therapy to the patient.

B. Future Work

The presented algorithm turned out to be sensitive to model inconsistencies like hysteresis, disturbances like spontaneous voluntary muscle activity and measurement noise. Therefore future research will focus on the reduction of the degrees of freedom by introducing more previous knowledge to the identification algorithms. With a disturbance observer approach we will try to identify voluntary muscle activity in order to make the identification more robust.

REFERENCES

- [1] U. Ziemann, B. Corwell, and L. G. Cohen, "Modulation of plasticity in human motor cortex after forearm ischemic nerve block," *Journal of Neuroscience*, vol. 18, no. 3, pp. 1115–1123, Feb. 1998.
- [2] A. Struppler, P. M. Havel, and P. Müller-Barna, "Facilitation of skilled finger movements by repetitive peripheral magnetic stimulation (RPMS) — A new approach in central paresis," *NeuroRehabilitation*, vol. 18, no. 1, pp. 69–82, May 2003.
- [3] A. B. Conforto, A. Kaelin-Lang, and L. G. Cohen, "Increase in hand muscle strength of stroke patients after somatosensory stimulation," *Annals of Neurology*, vol. 51, no. 1, pp. 122–125, Jan. 2002.
- [4] A. Struppler, B. T. Angerer, C. Gündisch, and P. M. Havel, "Modulatory effect of repetitive peripheral magnetic stimulation (RPMS) on the skeletal muscle tone (stabilization of the elbow joint) on healthy subjects," *Experimental Brain Research*, vol. 157, no. 1, pp. 59–66, 2004.
- [5] A. Pandyan, G. Johnson, C. Price, R. Curless, M. Barnes, and H. Rodgers, "A review of properties and limitations of the ashworth and the modified ashworth scales as measures of spasticity," *Clinical Rehabilitation*, vol. 13, no. 5, pp. 373–383, Oct. 1999.
- [6] B. Schmit and W. Rymer, "Identification of static and dynamic components of reflex sensitivity in spastic elbow flexors using a muscle activation model," *Annals of Biomedical Engineering*, vol. 29, no. 4, pp. 330–339, Feb. 2001.
- [7] L. Galiana, J. Fung, and R. Kearney, "Identification of intrinsic and reflex ankle stiffness components in stroke patients," *Experimental Brain Research*, vol. 165, no. 4, pp. 422–434, 2005.
- [8] B. Angerer, M. Bernhardt, M. Buss, D. Schröder, and A. Struppler, "Isometric muscle contraction induced by repetitive peripheral magnetic stimulation," in *Proceedings of the IFAC conference on Modelling and Control of Biomedical Systems (MCBMS)*, Sept. 2006, to appear.
- [9] B. T. Angerer, D. Schröder, and A. Struppler, "Nonlinear system identification of muscle contractions induced by repetitive peripheral magnetic stimulation," in *NOLCOS 2004 — Stuttgart Symposium on Nonlinear Control Systems, Preprints Volume 2*, IFAC. VDI/VDE, Sept. 2004, pp. 669–674.
- [10] O. Nelles, *Nonlinear System Identification — From Classical Approaches to Neural Networks and Fuzzy Models*. Heidelberg, Germany: Springer-Verlag, 2001.
- [11] K. S. Narendra and K. Parthasarathy, "Identification and control of dynamical systems using neural networks," *IEEE Transactions on Neural Networks*, vol. 1, no. 1, pp. 4–27, Mar. 1990.
- [12] D. Schröder, Ed., *Intelligent Observer and Control Design for Nonlinear Systems*. Heidelberg, Germany: Springer-Verlag, 2000.