

# Model-Mediated Teleoperation for Multi-Operator Multi-Robot Systems

Carolina Passenberg\*, Angelika Peer, and Martin Buss

Institute of Automatic Control Engineering (LSR), Technische Universität München, Germany

cpassenberg@lsr.ei.tum.de, angelika.peer@tum.de, m.buss@ieee.org

**Abstract**—Knowledge about the remote environment can be used in the control law to improve robustness and fidelity of haptic teleoperation systems. Model-mediated teleoperation adopts this idea by rendering an estimated model of the remote environment on local site instead of transmitting force/velocity flows. In this paper, we extend the original model-mediated teleoperation approach to multi-operator multi-robot teleoperation systems. A theoretic robustness and fidelity analysis is conducted. The theoretical results show a superior performance of the proposed method compared to a classic bilateral approach. Experimental results confirm the practical efficiency of the presented approach.

## I. INTRODUCTION

Multi-operator multi-robot (MOMR) teleoperation systems provide multiple human operators with the ability to jointly perform complex tasks in a common remote environment while simultaneously receiving multi-modal feedback. As illustrated in Fig. 1, in a haptic MOMR teleoperation system, each operator controls one teleoperator or slave device via a corresponding master device. The signals are exchanged over a communication channel. For the controller design of teleoperation systems, two important, but conflicting, quantitative performance measures are *robustness* and *fidelity*. A robustly stable controller is important due to the unstructured, varying and potentially unknown behavior of operator, remote environment and communication channel. A high degree of fidelity is desirable, as it allows an accurate display of the remote environment to the operator.

System-specific parameters like actuator and sensor deficiencies as well as time delay or packet loss in the communication channel negatively affect robustness and fidelity. For single-user systems, a large number of teleoperation control architectures have been proposed to guarantee robust stability or to improve fidelity, see [1] for an extensive survey. Only a few approaches are transferred to collaborative manipulation tasks in MOMR teleoperation systems. These include  $\mu$ -synthesis-based robust control designs [2], adaptive controllers [3] and event-based distributed controllers [4].

When additional knowledge about the environment, the operator or the task is incorporated in the controller structure, performance improvements can be achieved without risking robust stability. A variety of approaches has been proposed for single-user systems in this context which are summarized in [5]. One of these approaches is referred to as *model-mediated* (MM) or *VR-based teleoperation*. This approach allows to significantly increase the bandwidth in teleoperation systems with arbitrary time delay in the communication channel. The idea is to couple the master to a local estimated, virtual model of the remote environment [6], [7], [8], [9],

[10], [11] instead of using transmitted positions/velocities or forces. This approach has been investigated for contact situations in single-user teleoperation systems with and without time delay. Experiments have shown significant improvements in terms of fidelity [11] and perceived realism of the remote objects [7].

In this paper, we investigate the transferability of model-mediated teleoperation to typical multi-user scenarios such as the transportation of a movable rigid object. We assume two operators at a common local site and two teleoperators at a remote place with negligible time delay in the communication channel. The teleoperators are directly coupled to the object by, for example, grasping the object. Thus, pushing and pulling forces can be applied. The idea of model-mediated teleoperation is, that instead of closing the loop over the teleoperators holding and moving the object, the operators are locally coupled with each other through an estimated model of the remote object. Thus, the actions and reactions of the operators are exchanged without any delay over the virtual object. This is expected to increase the bandwidth of the overall system without risking stability. The expected improvements in terms of robustness and fidelity are shown in a theoretical comparison between the model-mediated teleoperation approach and two independent bilateral controllers with fixed parameters. Furthermore, the approach is evaluated experimentally on a one degree-of-freedom (DOF) MOMR teleoperation system.

The paper is structured as follows: model and estimation algorithm for the remote object are presented in Sec. II together with the teleoperation control architecture. Results of the robustness and fidelity analysis are reported in Sec. III. Experimental results are presented in Sec. IV. Finally, the paper finishes with a summary and outlook in Sec. V.

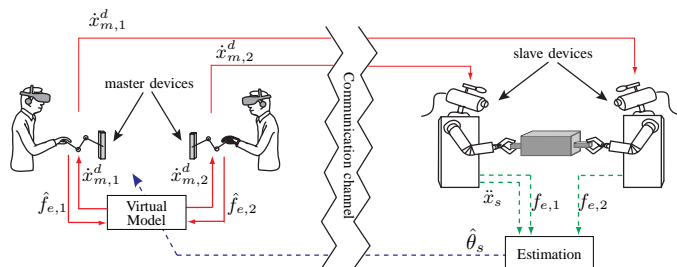

Fig. 1. Model-mediated teleoperation architecture for MOMR systems

## II. MODEL-MEDIATED TELEOPERATION APPROACH

The control architecture for model-mediated teleoperation for MOMR systems is shown in Fig. 1. The main parts of this architecture are the estimation of a model of the remote

object as well as the representation of the estimated model on master site. The following section introduces first the model and estimation algorithm for the remote object and second a detailed description of the overall control architecture.

#### A. Modeling and estimation of the remote object

For applying model-mediated teleoperation to multi-user systems, an estimated model of the manipulated remote object is required. The modeling of the object's dynamics is hereby based on the following assumptions, see Fig. 2:

- The two teleoperators rigidly grasp the movable remote object. Thus, each operator can apply pushing and pulling forces without dropping the object.
- The object is rigid, i.e. the relative position between the two slave devices and between each slave device and the middle of the object is constant  $x_{s1} - x_{s2} = c_1$ ,  $x_{s1} - x_o = c_2$ ,  $x_{s2} - x_o = c_3$ , with  $c_1, c_2, c_3$  constants. This implies

$$\dot{x}_{s1} = -\dot{x}_{s2} = \dot{x}_o \text{ and } \ddot{x}_{s1} = -\ddot{x}_{s2} = \ddot{x}_o.$$

- The object is lifted, not pushed over the ground. Thus, friction can be neglected.
- The end-effector masses of the slave devices are known.

In summary, the remote object can be described as a movable mass.

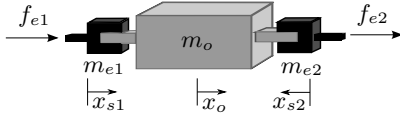

Fig. 2. Forces acting on a rigidly grasped object

The force that leads to an acceleration of the object is determined by

$$f_{e1} + f_{e2} - (m_{e1} + m_{e2})\ddot{x}_o = m_o\ddot{x}_o.$$

For the estimation of the object's mass, a recursive least squares (RLS) algorithm is chosen. Although there exists many RLS schemes with various modifications, the classic RLS algorithm without further modifications is selected for the estimation of the object's mass  $\hat{m}_o$  due to its fast convergence speed and disturbance rejection. The tracking properties of the algorithm are less important, as an object is usually carried over a longer distance and, thus, the parameters do not change rapidly compared to the convergence speed of the algorithm. The classic RLS algorithm furthermore ensures, that the estimation does not fluctuate. This is important, as the estimated parameter is directly used in the centralized controller on master site.

For practical realization, the acceleration of the object has to be measured using an acceleration sensor. Due to the assumption of a rigid object, i.e.  $\ddot{x}_{s1} = -\ddot{x}_{s2}$ , one sensor is sufficient and can be mounted on one of the slave devices.

#### B. Control architecture

The idea of model-mediated teleoperation consists in replacing the measured slave-object-slave interaction on remote site with a locally applied, estimated model of this interaction. For MOMR systems, under the assumption, that

the remote object is jointly manipulated, this requires a centralized controller on master site. We propose a coupling between the two master devices using a common position-based admittance controller as first proposed in [12]. The control architecture for the proposed model-mediated control approach is shown in Fig. 3. The admittance transforming the input force into a desired velocity for the underlying velocity controller is used to render desired virtual dynamics to the operators. This dynamics can be used to display the estimated dynamics of the remote object characterized by  $\hat{m}_o$  to the operators. Thus, for model-mediated teleoperation in MOMR systems the dynamics on master site is given by

$$f_{h1}(t) + f_{h2}(t) = \hat{m}_o\ddot{x}_{m1,2}^d(t), \quad (1)$$

where  $f_{h1}, f_{h2}$  are the applied forces of operator one and two and  $\ddot{x}_{m1,2}^d$  is the desired acceleration of the master devices one and two. The desired master velocity is also sent to the remote site and tracked using stiff PI-controllers implemented in the slave devices. Through the common admittance controller on local site the two master devices are rigidly coupled with each other. Thus, the assumptions about a rigid interaction between the slave devices and the object are met on master site as well. Interactive forces, i.e. forces that do not result in a movement of the object as defined in [13], are exchanged between the two operators locally. They are, however, not transmitted from master to slave site as they are by definition not observable in the sent velocities.

For free space motions, i.e. if there is no interaction between the slave devices, separate bilateral position-based admittance controllers are used for the two master-slave systems.

### III. ROBUSTNESS AND FIDELITY ANALYSIS

For evaluating the performance of the proposed approach an analytic stability and fidelity analysis is conducted for the slave-object-slave interaction. It is assumed, that all devices are identical. Then, a numerical analysis is conducted for the experimental setup used in this paper and the performance is compared with the performance of the two independent bilateral controllers with fixed parameters.

#### A. Robustness

This section addresses stability of the MM architecture under varying masses of the remote objects. As the measured force feedback from the remote site is replaced by a local estimated virtual model in MM teleoperation, instead of proving stability for the system closed over the communication channel, two stability proofs, one for the locally closed master system and one for the closed slave system should be conducted. It is assumed, that the velocity controllers for the slave devices are tuned as stiff as possible without risking stability of the slave-object-slave system. Thus, in this paper, only the centralized controller is tested for input-output (I/O) stability. A system is I/O-stable, if the poles of the closed-loop transfer function are shown to have strictly negative real parts [14]. In a first step, the closed-loop transfer function  $G_{hoh} = \frac{\dot{X}_{m1,2}}{F_d}$  on master site is calculated. This is achieved

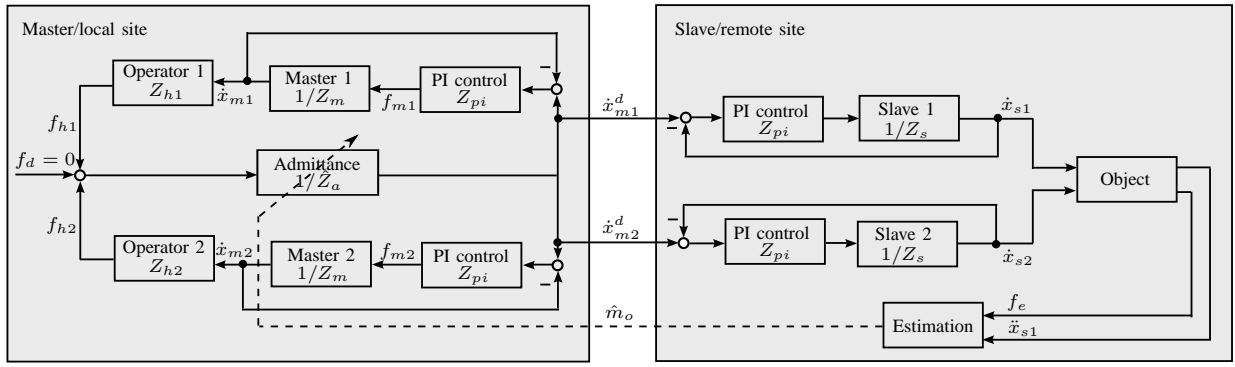

Fig. 3. Block diagram of MOMR model-mediated teleoperation for slave-object-slave interaction

by modeling the controllers directly in the Laplace domain. Variables with capital letters are Laplace-transformed and  $s$  stands for the Laplace operator.

For the operators, a passive arm impedance is assumed and the bandwidth limitations of the force measurements are modeled as a low-pass filter with time constant  $T_f$

$$\frac{F_{h1,2}}{\dot{X}_{m1,2}} = Z_{h1,2} = \underbrace{\frac{1}{T_f s + 1}}_{\text{force filter}} \underbrace{m_{h1,2}s + d_{h1,2} + k_{h1,2}}_{=Z_{h1,2} \text{ arm impedance}} \frac{1}{s} \quad (2)$$

Identical PI controllers are implemented on the two master devices as local velocity controllers:

$$\frac{F_{m1,2}}{\dot{E}_{m1,2}} = Z_{pi} = K_i \frac{1}{s} + K_p \quad (3)$$

with  $\dot{E}_{m1,2} = \dot{X}_{m1,2}^d - \dot{X}_{m1,2}$ . Furthermore, actuator dynamics and a simplified mass-damper system are assumed

$$\frac{F_{m1,2}}{\dot{X}_{m1,2}} = Z_m = \underbrace{(T_a s + 1)}_{\text{actuator dyn.}} \cdot \underbrace{(m_m s + d_m)}_{\text{device dyn.}} \quad (4)$$

where  $T_a$  represents the actuator time constant and  $m_m, d_m$  are mass and damping of the devices. The variable admittance in the Laplace domain is

$$\frac{\dot{X}_{m1,2}^d}{F_{h1} + F_{h2}} = \hat{Z}_a = \hat{m}_o s. \quad (5)$$

Furthermore, operator forces acting directly on the devices are assumed to be compensated. The closed-loop transfer function of the system is derived based on the elements of the  $\mathbf{H}$ -matrix, introduced by [15]

$$\begin{bmatrix} F_{h1} \\ -\dot{X}_{m2} \end{bmatrix} = \mathbf{H}^{hoh} \begin{bmatrix} \dot{X}_{m1} \\ F_{h2} \end{bmatrix}. \quad (6)$$

For the proposed architecture, the  $\mathbf{H}$ -matrix is given as

$$\mathbf{H}^{hoh} = \begin{bmatrix} h_{11} & h_{12} \\ h_{21} & h_{22} \end{bmatrix} \quad (7)$$

$$= \begin{bmatrix} \frac{\hat{Z}_a (Z_m + Z_{pi})}{\hat{Z}_a + Z_{pi}} & \frac{Z_{pi}}{\hat{Z}_a + Z_{pi}} \\ -\frac{Z_{pi}}{\hat{Z}_a + Z_{pi}} & \frac{Z_{cm} (\hat{Z}_a + Z_{pi})}{Z_{cm} (\hat{Z}_a + Z_{pi})} \end{bmatrix}. \quad (8)$$

With these model assumptions a closed-loop transfer function for the human-object-human interaction is obtained

$$G_{hoh} = \frac{h_{22} Z_{h2,1} + 1}{(h_{22} Z_{h2,1} + 1) Z_{h1,2} + \det(\mathbf{H}^{hoh}) Z_{h2,1} + h_{11}} \quad (9)$$

### B. Fidelity

A second important objective for the controller design of teleoperation systems is *transparency*. A teleoperation system is called transparent, if the technical system between operator and environment is not felt. Lawrence [16] formulated this definition in the frequency domain as the equality of the impedance transmitted to the operator  $Z_t$  and the impedance of the environment  $Z_e$  and the equality of master and slave velocities

$$Z_t|_{F_e^*=0} = \frac{F_h}{\dot{X}_m} = Z_e|_{F_h^*=0} = \frac{F_e}{\dot{X}_s} \text{ and } \dot{X}_m = \dot{X}_s. \quad (10)$$

This definition implies zero forces in free space and an exact representation of remote objects and/or the impedance behavior of further human operators during contact. For evaluation, the degree of *fidelity*, i.e. the distance of a system from being transparent, is used. One fidelity measure is the transparency error  $Z_{error}$  as introduced by [16], which quantifies the difference between the real/ideal environment impedance  $Z_e^*$  and the felt transmitted impedance  $Z_t^* = Z_t|_{Z_e^*}$ . It is calculated as the area between the absolute values of these two curves over a certain frequency range  $[\omega_{min}; \omega_{max}]$ :

$$Z_{error} = \frac{1}{\omega_{max} - \omega_{min}} \int_{\omega_{min}}^{\omega_{max}} |Z_{diff}(j\omega)|^2 d\omega \quad (11)$$

with

$$Z_{diff}(j\omega) = |\log Z_e^*(j\omega)| - |\log Z_t^*(j\omega)|.$$

A first generalization of the definition of transparency to multi-operator single-robot systems (MOSR) has been proposed by Khademian & Hashtrudi-Zaad [17], [18]. In this paper, we extend the definition of transparency for single-user systems to MOMR systems. We call this measure *co-transparency* in order to emphasize the cooperative aspect.

**Definition.** A multi-user system is called *co-transparent*, if the impedance transmitted to one user is equal to the impedance transmitted to the other users

$$Z_{t1}|_{F_{h2}^*=0} = \frac{F_{h1}}{\dot{X}_{h1}} = Z_{t2}|_{F_{h1}^*=0} = \frac{F_{h2}}{\dot{X}_{h2}}. \quad (12)$$

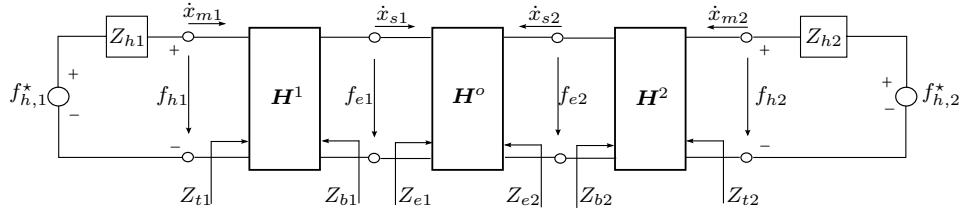

Fig. 4. Network representation of MOMR teleoperation system

This definition implies, that all operators perceive the environment in the same way. This condition is evaluated based on the network representation of the MOMR teleoperation system, see Fig. 4. The network matrices are defined as:

$$\begin{bmatrix} F_{h1,2} \\ -\dot{X}_{s1,2} \end{bmatrix} = \mathbf{H}^{1,2} \begin{bmatrix} \dot{X}_{m1,2} \\ F_{e1,2} \end{bmatrix} \quad (13)$$

$$\begin{bmatrix} F_{e1} \\ \dot{X}_{s2} \end{bmatrix} = \mathbf{H}^o \begin{bmatrix} \dot{X}_{s1} \\ F_{e2} \end{bmatrix} \quad (14)$$

Thus,  $Z_{t1,2}$  can be written as

$$Z_{t1} = \frac{h_{11}^1 + \det(\mathbf{H}^1)Z_{e1}}{1 + h_{22}^1 Z_{e1}} \quad Z_{t2} = \frac{h_{11}^2 + \det(\mathbf{H}^2)Z_{e2}}{1 + h_{22}^2 Z_{e2}} \quad (15)$$

with

$$Z_{e1} = \frac{h_{11}^o + \det(\mathbf{H}^o)Z_{b2}}{1 + h_{22}^o Z_{b2}} \quad Z_{e2} = \frac{h_{11}^o + Z_{b1}}{\det(\mathbf{H}^o) + h_{22}^o Z_{b1}}$$

$$Z_{b1} = \frac{h_{11}^1 + Z_h}{\det(\mathbf{H}^1) + h_{22}^1 Z_h} \quad Z_{b2} = \frac{h_{11}^2 + Z_h}{\det(\mathbf{H}^2) + h_{22}^2 Z_h}$$

Thus, the transmitted impedances  $Z_{t1,2}$  are equal, if

$$h_{11}^1 = h_{11}^2 \wedge h_{22}^1 = h_{22}^2 \wedge h_{12}^1 h_{21}^1 = h_{12}^2 h_{21}^2 \quad (16)$$

and

$$\det(\mathbf{H}^o) = 1. \quad (17)$$

This means, that the overall architecture has to be symmetric. A sufficient condition for meeting the conditions (16) is to use the same control architecture for master-slave system one and two. Equation (17) is always fulfilled in free space, i.e. if there is no contact between the slave-object-slave system and the surrounding remote environment. The proposed control architecture satisfies this property and the overall system is therefore co-transparent. If the system is co-transparent, it is also sufficient to examine the fidelity, i.e. the transmitted impedance, for one operator, as it is then by definition equal to the fidelity of the other. Therefore, the transmitted impedance to any operator is denoted by  $Z_t$ .

### C. Numerical analysis

In this section, the analytic expressions from Sec. III-A and III-B for robust stability and fidelity are evaluated for the experimental 1-DOF setup used in this paper. Assuming computed-torque controllers and, thus, decoupled DOFs, the MM control approach presented for this simplified 1 DOF system can be transferred to multi-DOF systems.

1) *Experimental setup*: Four identical linear actuators, Thrusttube modules 2504 from Copley Controls Corp., each equipped with an optical position encoder (resolution  $1 \mu\text{m}$ ) and a force sensor, as shown in Fig. 5, were used as multi-operator multi-robot teleoperation system. One slave

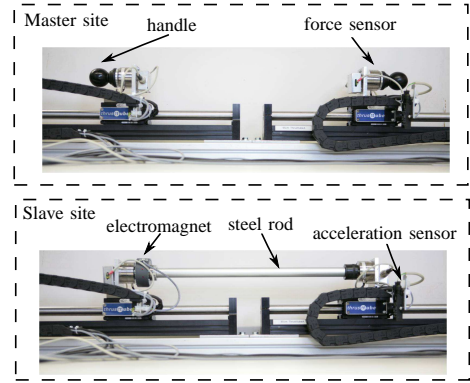

Fig. 5. Experimental setup: 1-DOF MOMR system

device was furthermore equipped with an acceleration sensor. Handles were mounted on the master devices. On one of the slave devices, a rigid steel rod was fixed as remote object. An electromagnet on the second slave device was used to couple both devices. The total mass was determined to 710 g. The end-effector masses  $m_{e,1}, m_{e,2}$  are zero. The following device and controller parameters are used:

Force filter	$T_f = 1/(2\pi \cdot 500) \text{ s}$
PI-controller	$K_i = 70.000 \text{ N/m}, K_p = 500 \text{ Ns/m}$
Actuator & device dynamics	$T_a = 0.00065 \text{ s}, m_m = 2.498 \text{ kg}$ $b_m = 20 \text{ Ns/m}$

2) *Robustness*: Besides device and controller parameters, the human arm impedances have to be determined for the evaluation of the transfer function  $G_{hoh}$  found in Sec. III-A. In order to decrease the conservativeness of the robustness analysis, upper and lower limits for the human arm dynamics are taken into account. Under the assumption that these parameters change simultaneously within one human the variation of the arm impedances can be described as  $Z_{h1/2} = Z_{h1/2,min} + \alpha_{1/2}(Z_{h1/2,max} - Z_{h1/2,min})$  with  $\alpha_{1,2} \in [0; 1]$ . The lower bound for the impedance is zero, while the upper bounds, taken from [19], are  $m_{h,max} = 1.2 \text{ kg}$ ,  $b_{h,max} = 5 \text{ Ns/m}$ , and  $k_{h,max} = 60 \text{ N/m}$ . In the analysis, the factor  $\alpha = \frac{\alpha_1 + \alpha_2}{2}$  is varied from zero to one. By testing the system on master site for I/O-stability, stability boundaries for the object mass depending on  $\alpha$  are obtained as shown in Fig. 6.

The results show a positive relation between rigidity of grasp and minimum displayable object mass. In order to guarantee stability for all types of grasp the lowest

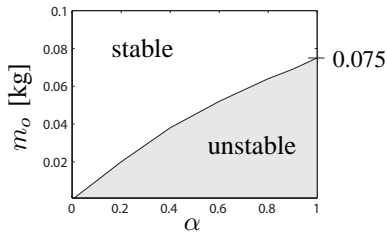

Fig. 6. Stability region of object mass depending on rigidity of operators grasp  $\alpha$

displayable mass is 75 g. Thus, there exists a lower bound for the object's mass to be rendered realistically. The theoretical results are confirmed on the experimental setup. The two master devices were rigidly connected via a common virtual admittance with constant mass and no damping. For a virtual mass below 80 g, vibrations were observed.

3) *Fidelity*: In the following, the fidelity for the proposed approach is analyzed based on the transparency error. The ideal environment  $Z_e^*$  is hereby chosen as a serial connection of the impedance of the remote object  $Z_o$  and the human arm  $Z_h$ , i.e.  $Z_e^* = Z_o + \alpha Z_h$ . If  $\alpha = 0$ ,  $Z_e^*$  represents an object only. If another operator holds on to the object via a teleoperation system, ideally only his or her arm impedance  $\alpha Z_h$ ,  $\alpha \neq 0$ , is connected in series with the impedance of the object, while the dynamics of the teleoperation system is canceled out.

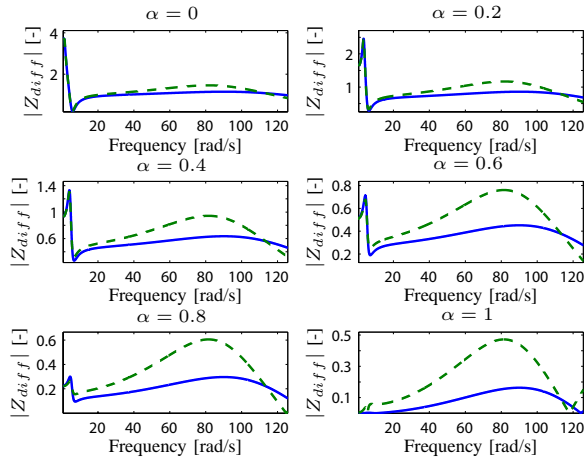

Fig. 7. Comparison of transparency error curves  $|Z_{diff}|$  for MM (solid) and FaFa (dashed) approach depending on  $\alpha$

The transparency error curve  $|Z_{diff}|$  is shown for  $\alpha = [0, 0.25, 0.5, 0.75, 1]$  in Fig. 7 for a frequency range of 0.1-20 Hz, which is a suitable range for most teleoperated tasks. The mass of the object is chosen as 710 g, which corresponds to the object's mass used in the experimental section. In order to make a qualitative statement about the proposed controller, its fidelity is compared with the fidelity of two independent bilateral position-based admittance controllers with force-force exchange (FaFa) between masters and slaves, see [20] for details. This architecture is co-transparent, if, for identical single-user teleoperation setups, the same control architectures and parameters are used. In

a first step, a robust stability analysis is conducted for this architecture. The stability boundary for the virtual mass in the admittance is 40 g for a range of 0 to 50 kg for the object's mass. The virtual damping is set to zero. Using these parameters, the transparency error curve is calculated and shown in Fig. 7. Furthermore, the transparency error  $Z_{error}$  as introduced in (11) is calculated for both approaches. As the transparency error for the MM approach is smaller than the one of the FaFa approach for all  $\alpha$ , the proposed architecture leads to an increased bandwidth, i.e. a higher degree of fidelity even for negligible time delay in the communication channel. The transparency errors for object only and object and maximum arm impedance are:

$$\begin{aligned} \text{MM approach: } & Z_{error}(\alpha = 0) = 156.23 & Z_{error}(\alpha = 1) = 1.20 \\ \text{FaFa approach: } & Z_{error}(\alpha = 0) = 199.28 & Z_{error}(\alpha = 1) = 9.71 \end{aligned}$$

#### IV. EXPERIMENTAL RESULTS

The MM control approach is validated experimentally on the described setup. The task consisted in connecting the two devices and describing sinusoidal motions.

The mass parameter of the estimation was initialized with  $\hat{m}_o(0) = 1$  kg. The estimation is activated, if the resulting force and the acceleration on slave site are above a threshold of 0.1 N and 0.1 m/s<sup>2</sup>, respectively. Regarding the estimation results, the important aspects are a fast convergence speed and an accurate, non-fluctuating estimation. In Fig. 8, the estimated mass  $\hat{m}_o$  is shown. After 300 ms the estimated

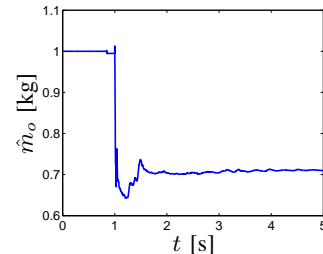

Fig. 8. Estimated object mass

parameter stays within a 5% bound around the final value. This shows a fast convergence speed of the algorithm and a convergence to an almost constant value. Also, the variation of the estimated parameter after the convergence time of the estimation is smaller than the just noticeable difference (JND) for mass (35% for the arm/forearm, see [21]), such that it cannot be felt by the operators. The final estimated mass of the object is roughly 711 g. The difference between estimated and true mass of the object is 0.14%, which is clearly below the JND. Thus, in summary, the estimation is very accurate and the operators cannot perceive a difference between true object and reconstructed object. The impression of the object during the convergence time of the estimation is determined by the initial value of the estimation.

For MOMR teleoperation systems, the most important aspects are robustness and fidelity. The observed behavior was always stable, i.e. moving in free space, establishing contact with the object and moving the object did not lead to

oscillations or instabilities. A high degree of fidelity requires a good position tracking as well as a good force tracking. As the desired master velocities are tracked using a high-gain PD-controller on slave site, only the dynamics of the underlying master and slave velocity control loops can be observed when comparing master and slave velocities. Thus, the tracking error is small. Regarding force tracking, the

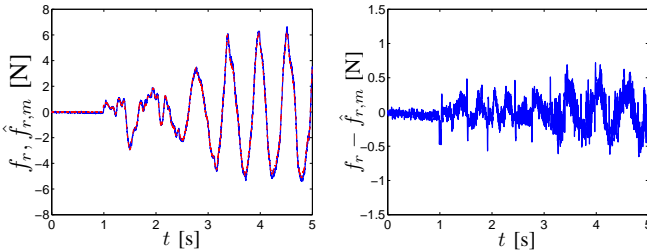

Fig. 9. Left: Measured resulting force on slave site (solid) and virtual resulting force on master site (dashed), right: force error

resulting force  $f_r$  measured on slave site and the virtual resulting force  $\hat{f}_{r,m}$  reconstructed with the estimated object mass on master site are compared with each other, see Fig. 9. The virtual force fits well with the measurements. Furthermore, the normalized root-mean-square error (NRMSE) between measured and reconstructed resulting force

$$NRMSE = 1/(f_{r,max} - f_{r,min}) \sqrt{\sum_{n=1}^N (f_{r,n} - \hat{f}_{r,m,n})^2 / N}.$$

is 1.76% for the given object and trial. Thus, also the force tracking is good. This shows the practical efficiency of the model-mediated teleoperation control approach for MOMR systems.

## V. CONCLUSION

In this paper, we presented the extension of the model-mediated teleoperation approach to multi-user systems. We propose the coordination of the master devices using one centralized variable position-based admittance controller in such a way that it mimics the coupling of the teleoperators via a common stiff object as accurately as possible. The proposed approach is validated on a 1 DOF MOMR teleoperation system. In a theoretical analysis, it is shown, that the proposed approach leads to an improved fidelity of a MOMR teleoperation system beyond the level of decentralized controllers with constant parameters even for negligible time delay. Experimental results show the practical efficiency of the approach.

Future work consists in the extension of the approach to systems with 6 DOF and to constrained motions. For a qualitative evaluation in terms of feeling of presence/copresence, a user study needs to be conducted.

## VI. ACKNOWLEDGMENTS

This work is supported in part by the German Research Foundation (DFG) within the collaborative research center SFB453 "High-Fidelity Telepresence and Teleaction".

## REFERENCES

- [1] P. F. Hokayem and M. W. Spong, "Bilateral teleoperation: an historical survey," *Automatica*, vol. 42, pp. 2035–2057, 2006.
- [2] S. Sirouspour, "Robust control design for cooperative teleoperation," in *IEEE International Conference on Robotics and Automation*, 2005, pp. 1133–1138.
- [3] S. Sirouspour and P. Setoodeh, "Multi-operator/multi-robot teleoperation: an adaptive nonlinear control approach," in *IEEE/RSJ International Conference on Intelligent Robots and Systems*, 2005, pp. 1576–1581.
- [4] W. tai Lo, Y. Liu, I. Elhajj, N. Xi, Y. Wang, and T. Fukuda, "Cooperative teleoperation of a multirobot system with force reflection via internet," *IEEE/ASME Transactions on Mechatronics*, vol. 9, pp. 661–670, 2004.
- [5] C. Passenberg, A. Peer, and M. Buss, "A survey of environment-operator-, and task-adapted controllers for teleoperation systems," *Journal of Mechatronics*, 2010.
- [6] A. Achhammer, C. Weber, A. Peer, and M. Buss, "Improvement of model-mediated teleoperation using a new hybrid environment estimation technique," in *IEEE International Conference on Robotics and Automation*, 2010, pp. 5358–5363.
- [7] C. Weber, V. Nitsch, U. Unterhinninghofen, B. Färber, and M. Buss, "Position and force augmentation in a telepresence system and their effects on perceived realism," in *WorldHaptics*, 2009, pp. 226–231.
- [8] F. Mobasser and K. Hashtrudi-Zaad, "Predictive teleoperation using laser rangefinder," in *IEFE CCECE/CCGEI*, 2006, pp. 1279–1282.
- [9] S. Clarke, G. Schillhuber, M. F. Zaeh, and H. Ulbrich, "Prediction-based methods for teleoperation across delayed networks," *Multimedia Systems*, vol. 13, pp. 253–261, 2008.
- [10] P. Mitra and G. Niemeyer, "Model-mediated Telemanipulation," *The International Journal of Robotics Research*, vol. 27, pp. 253–262, 2008.
- [11] C. Tzafestas, S. Velanas, and G. Fakiridis, "Adaptive impedance control in haptic teleoperation to improve transparency under time-delay," in *IEEE International Conference on Robotics and Automation*, 2008, pp. 212–219.
- [12] D. Feth, R. Groten, A. Peer, S. Hirche, and M. Buss, "Performance related energy exchange in haptic human-human interaction in a shared virtual object manipulation task," in *WorldHaptics*, 2009, pp. 338–343.
- [13] R. Groten, D. Feth, H. Goshy, A. Peer, D. A. Kenny, and M. Buss, "Experimental analysis of dominance in haptic collaboration," in *The 18th International Symposium on Robot and Human Interactive Communication*, 2009, pp. 723–729.
- [14] J. Lunze, *Regelungstechnik 1*. Springer-Verlag Berlin Heidelberg, 1999.
- [15] B. Hannaford, "A design framework for teleoperators with kinesthetic feedback," *IEEE Transactions on Robotics and Automation*, vol. 5, pp. 426–434, 1989.
- [16] D. Lawrence, "Stability and transparency in bilateral teleoperation," *IEEE Transactions on Robotics and Automation*, vol. 9, pp. 624–637, 1993.
- [17] B. Khademian and K. Hashtrudi-Zaad, "A four-channel multilateral shared control architecture for dual-user teleoperation systems," in *IEEE/RSJ International Conference on Intelligent Robots and Systems*, 2007, pp. 2660–2666.
- [18] —, "Novel shared control architectures for enhanced users interaction in haptic training simulation systems," in *IEEE/RSJ International Conference on Intelligent Robots and Systems*, 2009, pp. 886–892.
- [19] T. Tsuji, P. G. Morasso, K. Goto, and K. Ito, "Human hand impedance characteristics during maintained posture," *Biological Cybernetics*, vol. 72, pp. 475–485, 1995.
- [20] A. Peer and M. Buss, "Robust stability analysis of a bilateral teleoperation system using the parameter space approach," in *IEEE/RSJ International Conference on Intelligent Robots and Systems*, 2008, pp. 2350–2356.
- [21] G. L. Beauregard and M. A. Srinivasan, "The manual resolution of viscosity and mass," *ASME Dynamic Systems and Control Division*, vol. 1, pp. 657–662, 1995.